

Глушители

Используются для снижения уровня шума при выхлопе воздуха из распределителя.

BSL

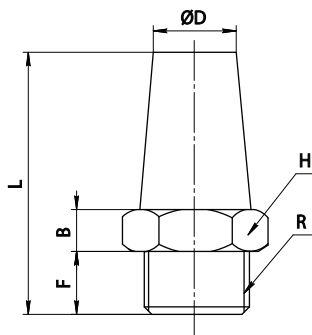

Модель	R	ØD	B	F	L	S
BSL-M5	M5	5.5	3.5	5	20	10
BSL-01	R1/8	8	4	6	24	13
BSL-02	R1/4	11	4	8	33	17
BSL-03	R3/8	14	5	10	44	22
BSL-04	R1/2	18	6.5	10	49	24
BSL-06	R3/4	21	7.5	11	57	30
BSL-10	R1	27	8.5	15.5	72	36
BSL-12	R1-1/4	32	8	15	77	46
BSL-14	R1-1/2	38	8.5	15	83	52
BSL-20	R2	50	9	17	5	64

BSLM

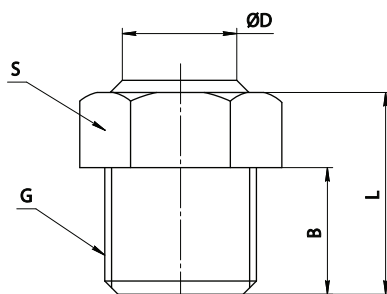

Модель	G	B	L	S	ØD
BSLM-01	G1/8	6	11	12	10
BSLM-02	G1/4	8.5	14.5	16	13
BSLM-03	G3/8	10	17	19	16
BSLM-04	G1/2	11	19	22	17
BSLM-06	G3/4	11.5	19.5	27	22
BSLM-10	G1	12.5	20.5	34	30

PSL

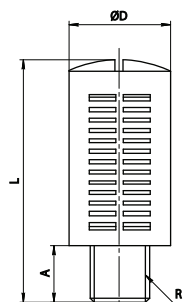

Модель	L	A	ØD	R
PSL-01	30	6	15.6	R1/8"
PSL-02	38.7	8	19.3	R1/4"
PSL-03	51	10	24	R3/8"
PSL-04	51	10	24	R1/2"

BESLD

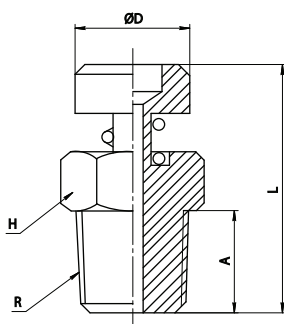

Модель	L	A	ØD	R	H
BESLD 01	25	6	12	R1/8"	17
BESLD 02	30.5	8.5	14	R1/4"	19
BESLD 03	34	10	17	R3/8"	22
BESLD 04	35	11	20	R1/2"	27
BESLD 06	37.5	11.5	25	R3/4"	30
BESLD 08	40.5	12.5	30	R1"	36